

Embedded TechTrends

*Advances in Digitizers Drive Mil/Aero & High
Energy Physics Applications*

Justin Moll
Director of Marketing, VadaTech
www.VadaTech.com



Architecture Wars

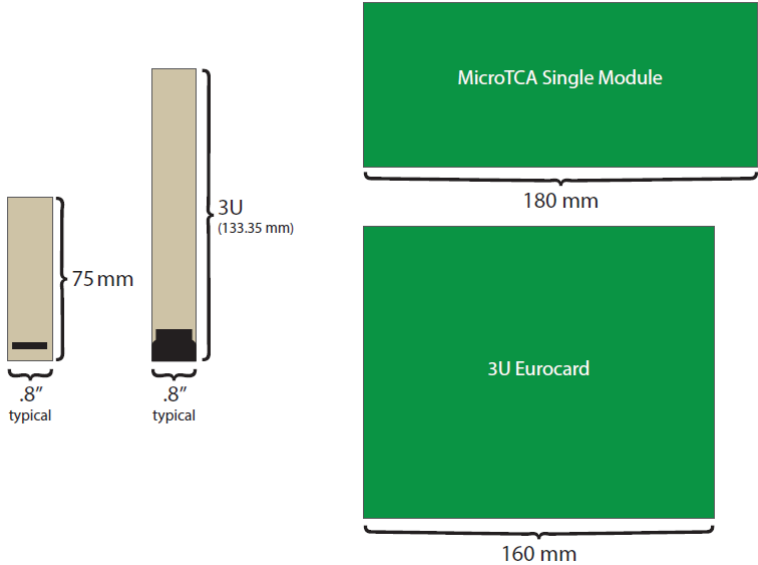

AMC and FMC – A/D & D/A

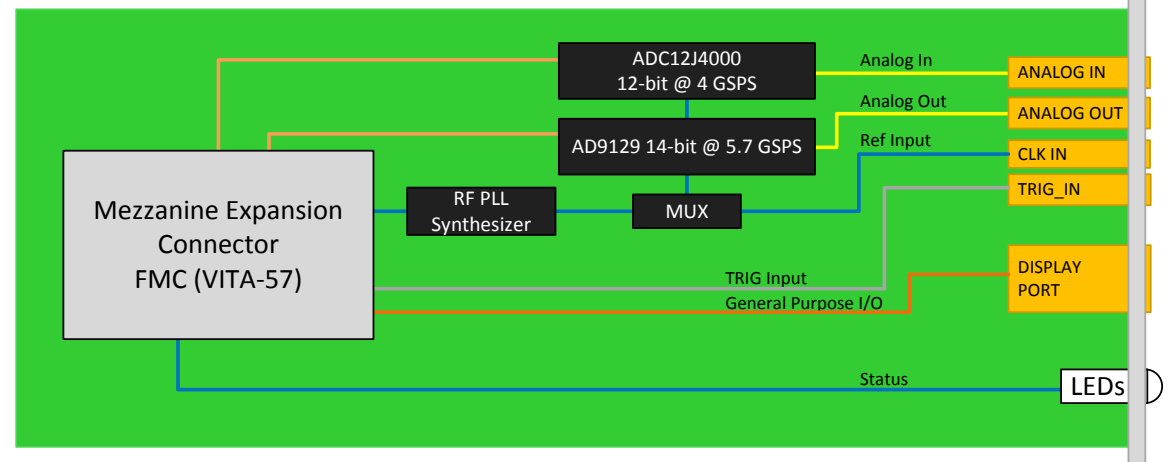
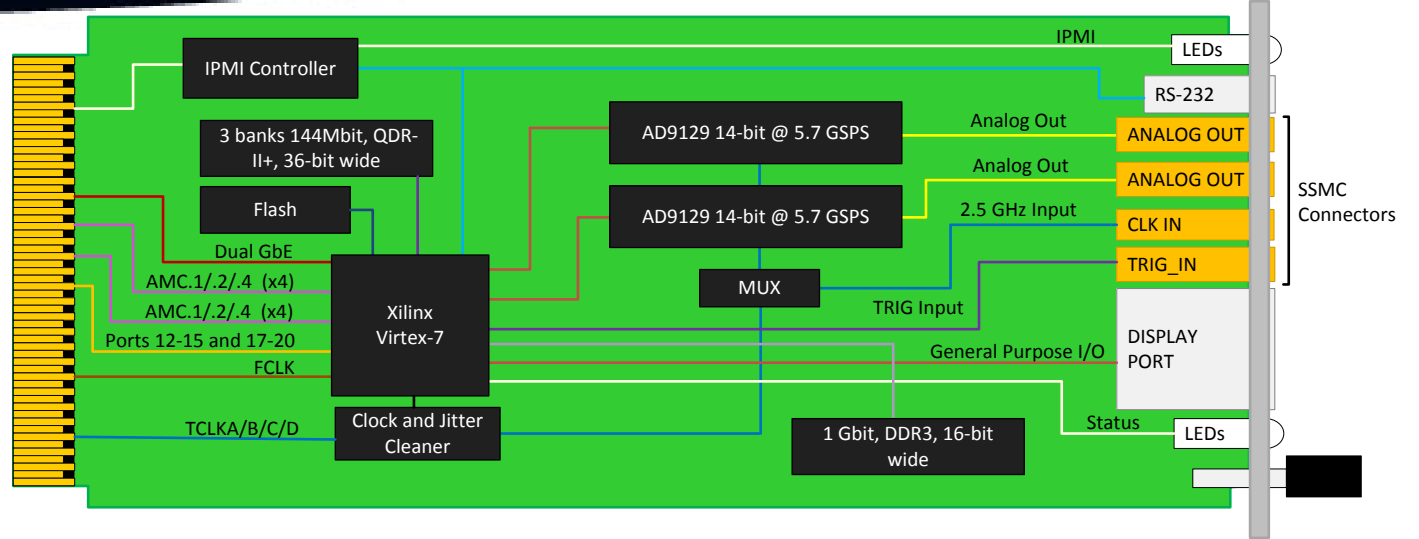
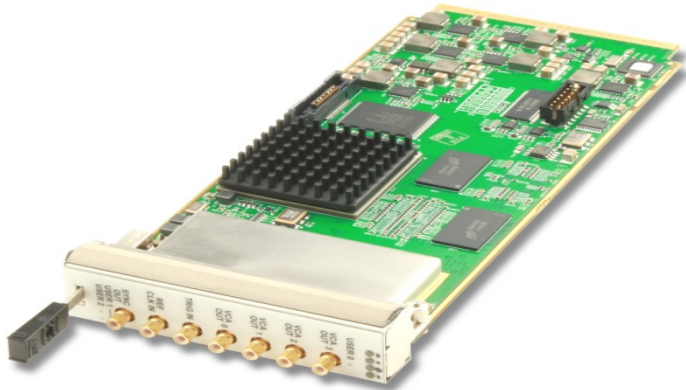

FPGA Carrier for FMCs

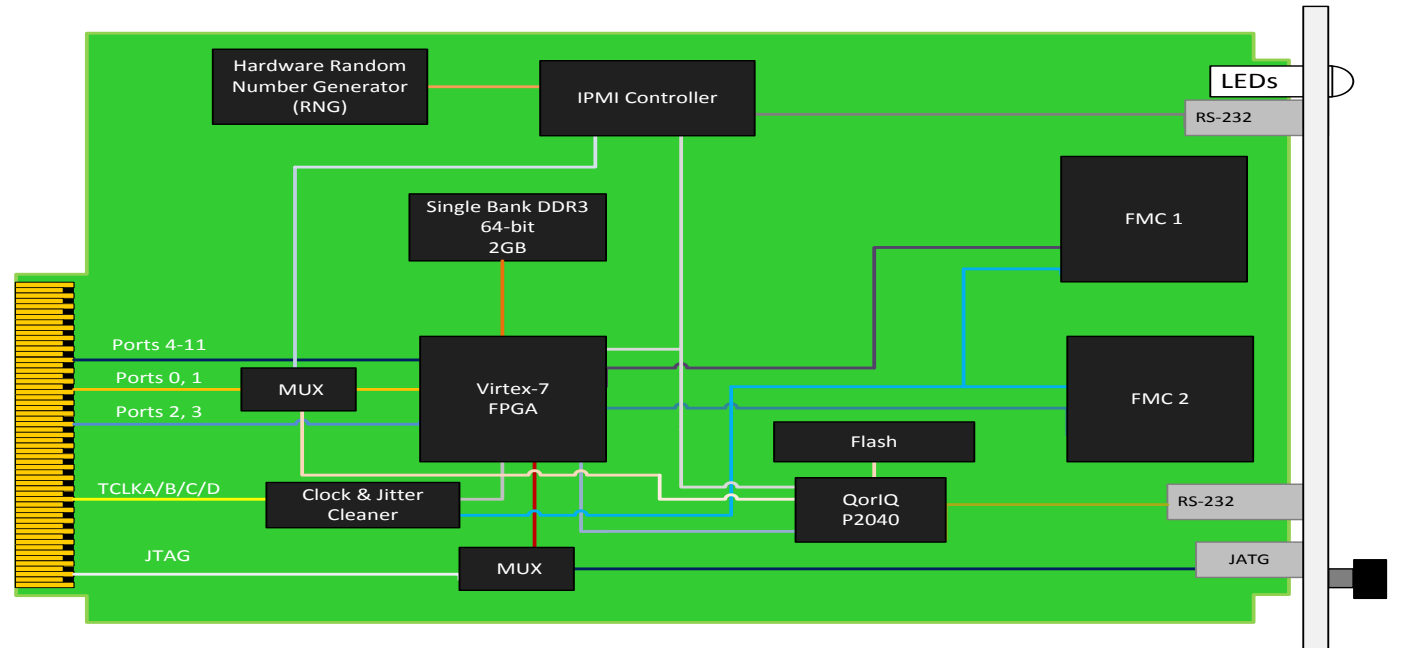
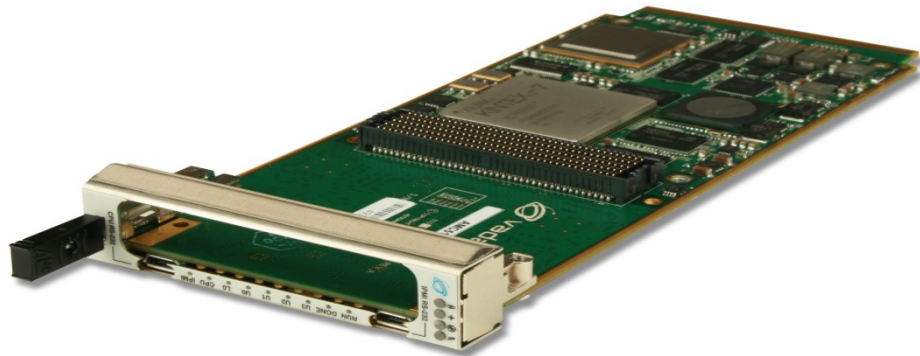

SWaP-C in Rugged MOXA Chassis Platforms

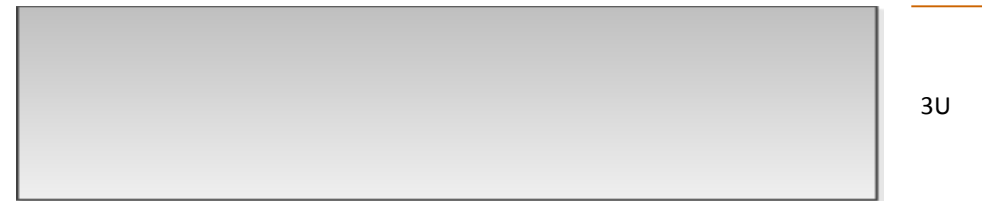

3x Virtex-7 AMC with 5.7 GSPS DAC and 4.0 GSPS ADC FMCs

+

1x Intel Core i-7 processor AMC

+

1x Advanced RAID AMC (0, 1, 5, 6 10, 50, 60)

+

1x JBOD Carrier AMC – up to 8 TB SDD storage

MTCA.4 A/D and D/A Converters

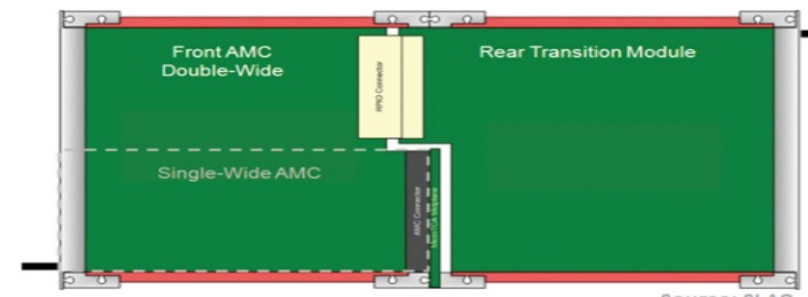
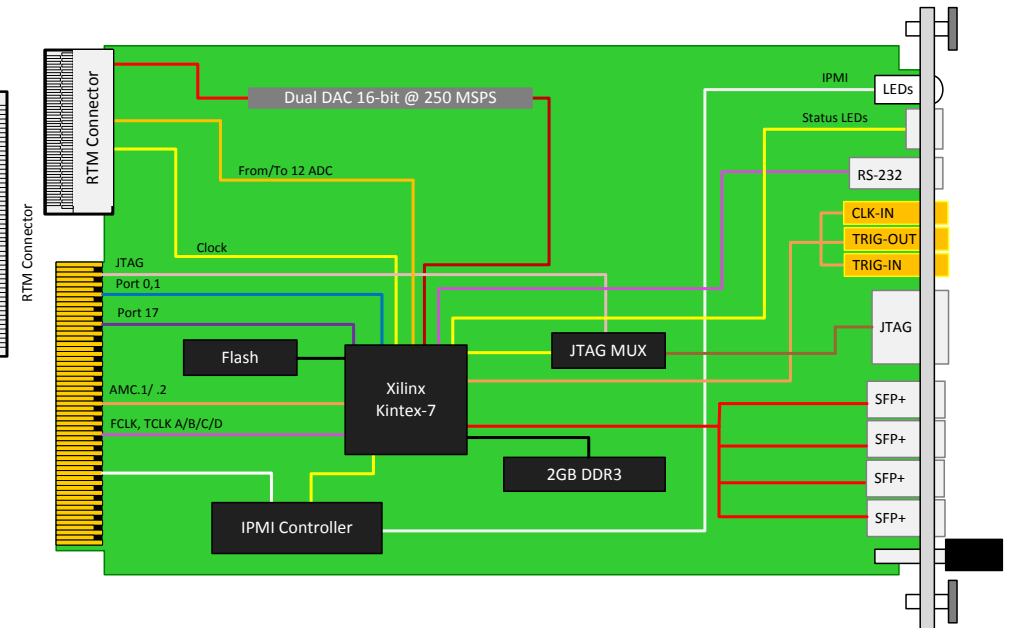
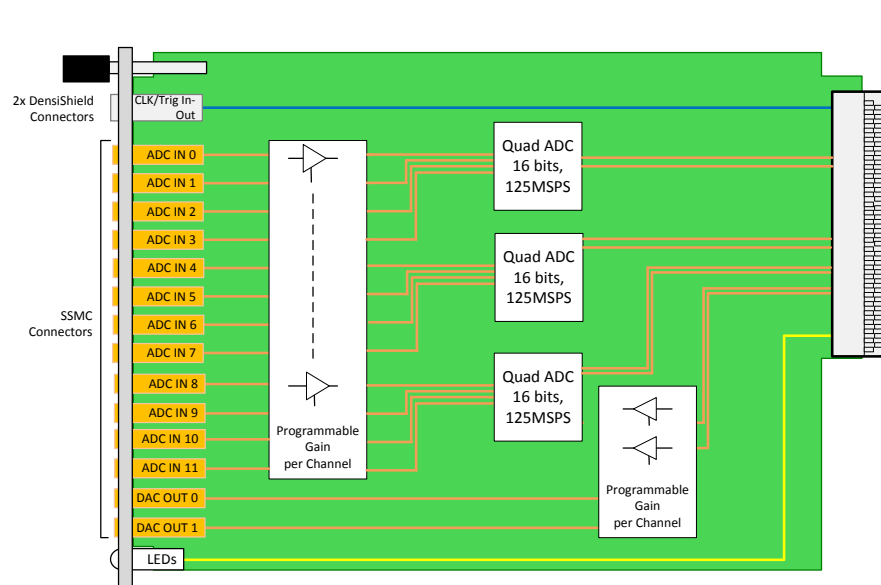

Source: SLAC

MicroTCA.4 System Platforms

